



Pioneer Network™

# Pioneering a New Culture of Aging Conference

**AUGUST 12-15, 2018**

Sheraton Denver Downtown Hotel  
Denver, Colorado

PIONEER NETWORK 2018 NATIONAL CONFERENCE PROGRAM



**Pioneer  
Network™**

[pioneernetwork.net](http://pioneernetwork.net)  
#PioneerNet2018

# Our 2018 Conference Exhibitors & Sponsors



- |  |   |  |   |
|--|---|--|---|
| AGE-u-cate Training Institute            | Haven Nursing Center                        | Metropolitan State University of Denver                                      | RCare, Inc.                                 |
| Alzheimer's Association of Colorado      | Hamilton CapTel                             | MobileServe  | Rockport Healthcare Services                |
| Ambient Activities Technology            | HealthCare Interactive                      | National Association of Activity Professionals                               | Schlegel-UW Research Institute for Aging    |
| Ben E. Keith Foods                       | Harloff Company                             | National Association of Activity Professionals Credentialing Center (NAAPCC) | Society of Certified Senior Advisors (SCSA) |
| The Beryl Institute                      | Health Professions Press                    | National Consumer Voice for Quality Long-Term Care                           | SWBR Architects                             |
| Colorado Culture Change Coalition (CCCC) | Joy for All Companion Pets                  | Person Centred Universe, Inc.  | TZMO USA, Inc./SENI                         |
| The Eden Alternative®                    | Kentucky Coalition for Person Centered Care |  | Varsity                                     |
| Fransen Pittman                          | LifeBio                                     |  | Wish of a Lifetime                          |
|  | LifeShare Technologies                      |  |   |
|  | Eli Lilly                                   |  |   |

OUR 2018 MEDIA SPONSOR



The news you need

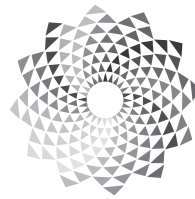

Pioneer Network

## Pioneering a New Culture of Aging Conference

**Welcome** TO THE 21ST ANNIVERSARY OF PIONEER NETWORK AND THE 2018 PIONEERING A NEW CULTURE OF AGING CONFERENCE! WE'RE COMING OF AGE THIS YEAR WITH MUCH TO CELEBRATE AND A SENSE OF EXCITEMENT AS WE LOOK TO THE FUTURE.

This year's Conference blends the old with the new, the traditions you love and expect like the Roll Call of States and Nations along with innovative ways to connect like the Tech Experience featuring some of the latest technology available in the world of aging.

We heard your feedback and we've brought back Guides who always draw a crowd and added many fresh faces and topics. We have intensive sessions on nine different topics and site visits that not only let you see and hear communities with pioneering programs but also let you see the sites and sounds of Denver and the Rocky Mountains. **We are here to "Promote the growth and development of all."**

Our Program this year is designed to bring our Values and Principles to life — starting with the Welcome Session on Sunday night where you'll begin to **"Know each person"** to our Coming of Age Party at Coyote Ugly where we'll **"Respond to spirit, as well as body and mind."** (See all of our Values and Principles on page 4.)

This is your Conference because all of us are **"Entitled to self-determination"** and we hope you take advantage of not only the educational opportunities that abound but also in creating new connections and deepening existing relationships. Our exhibit area is designed for you to connect with our Exhibitors and Sponsors as they share products and services that can support you on your person-centered journey, see the latest in technology, view the beautiful photographs of Elders, go through the Dementia Live experience and gather with each other. There are gathering places for quiet discussion or where you can engage with a lively and a robust group but always with others who share your passion and enthusiasm. **"Community is the antidote to institutionalization."**

And don't forget to go outside and get some Vitamin D in the Mile High City. A refreshing walk will get you energized for the mornings and afternoons ahead and allow you to **"shape and use the potential of the environment in all its aspects."** We invite you to enjoy all that Denver has to offer.

Join us in committing today and everyday to Pioneering a New Culture of Aging. Enjoy the Conference!



KaraLe Causey  
Chair, Board of Directors



Penny Cook  
President/CEO

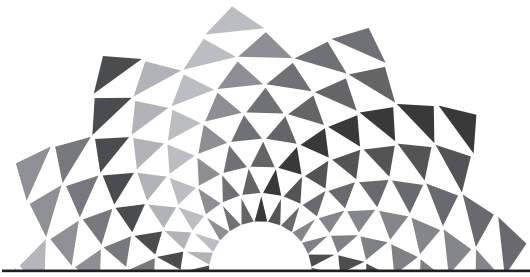

Pioneer Network

## Pioneering a New Culture of Aging Conference

### TABLE OF CONTENTS

Welcome Message	3
Our Values and Principles, Vision, and Mission	4
Conference Sponsors	5
Exhibitor & Sponsor Gallery Map	10
Make the Most of Your Conference Experience	11
General Conference Information	12
Conference Features	12
Conference Special Sessions	14
Morning General Session	14
Afternoon General Session	15
Schedule at a Glance	17
Monday, August 13	18
Concurrent Sessions A	18
Concurrent Sessions B	19
Concurrent Sessions C	20
Tuesday, August 14	21
Concurrent Sessions D	21
Concurrent Sessions E	22
Wednesday, August 15	23
Full Day Intensives	23
Half Day Intensives	24
Pioneer Network Board of Directors, Staff, Conference Staff, Education Committee	25
Special Thanks	26
Save the Date	27
Sheraton Floor Plan	28



### VALUES AND PRINCIPLES

- ◆ Know each person.
- ◆ Each person can and does make a difference.
- ◆ Relationship is the fundamental building block of a transformed culture.
- ◆ Respond to spirit, as well as mind and body.
- ◆ Risk-taking is a normal part of life.
- ◆ Put person before task.
- ◆ All elders are entitled to self-determination wherever they live.
- ◆ Community is the antidote to institutionalization.
- ◆ Do unto others as you would have them do unto you.
- ◆ Promote the growth and development of all.
- ◆ Shape and use the potential of the environment in all its aspects: physical, organizational, psycho/social/spiritual.
- ◆ Practice self-examination, searching for new creativity and opportunities for doing better.
- ◆ Recognize that culture change and transformation are not destinations but a journey, always a work in progress.

### OUR VISION

#### **A CULTURE OF AGING THAT IS LIFE-AFFIRMING, SATISFYING, HUMANE AND MEANINGFUL**

We recognize our need to create ways of living and working together that are different from the traditional models. Pioneer Network supports models where elders live in open, diverse, caring communities. Pioneers are working for deep system change by both evolutionary and revolutionary means, using Pioneer values and principles as the foundations for change — in-depth change in systems requires change in governmental policy and regulation; change in the individual's and society's attitudes toward aging and elders; change in elders' attitudes toward themselves and their aging; and change in the attitudes and behavior of caregivers toward those for whom they care. We refer to this work as culture change. Our aim is nothing less than transforming the culture of aging in America.

### OUR MISSION

Pioneer Network advocates and facilitates deep system change and transformation in our culture of aging. To achieve this, we:

- ◆ Create communication, networking and learning opportunities.
- ◆ Build and support relationships and community.
- ◆ Identify and promote transformations in practice, services, public policy and research.
- ◆ Develop and provide access to resources and leadership.

# 2018 Sponsors and Exhibitors

Special thanks to our sponsors, exhibitors, partners and friends who are making the 2018 Pioneer Network Conference a great success. We appreciate all you do to support our mission of facilitating deep systems change and transforming the culture of aging.



## Acts Retirement Life Communities, Inc.

[www.actsretirement.org](http://www.actsretirement.org)  
[cseeger@actslife.org](mailto:cseeger@actslife.org)

Acts Retirement-Life Communities® (ACTS) has been setting the standard for excellence in senior retirement living since opening its first community in 1972. With a vision founded in faith and guided by a commitment to integrity and loving-kindness, Acts has established an unsurpassed reputation for strength and stability in the senior retirement living industry. Acts Retirement-Life Communities is incorporated in Pennsylvania and is designated a 501(c) 3 charitable organization.

*Conference App Sponsor*



## AGE-u-cate Training Institute

[www.ageucate.com](http://www.ageucate.com)  
[renee@ageucate.com](mailto:renee@ageucate.com)

### Booth #28

AGE-u-cate® Training Institute develops and delivers research-based aging and dementia training programs for senior care providers across the spectrum.



## Alzheimer's Association

[www.alz.org](http://www.alz.org)  
[eshubeck@alz.org](mailto:eshubeck@alz.org)

### Booth #49

The Alzheimer's Association Dementia Care Practice Recommendations reflect the fundamentals of person-centered care, are based on current evidence and best practice, and outline dementia care across care settings and throughout the

disease. Learn about our Curriculum Review process and essentiALZ Certification program.

*Dementia Track Sponsor*



## Alzheimer's Association of Colorado

[www.alz.org/co](http://www.alz.org/co)  
[aschafer@alz.org](mailto:aschafer@alz.org)

For more than 25 years, the Alzheimer's Association Colorado Chapter has led the fight against Alzheimer's disease and related disorders by increasing the understanding of dementia and its impact on family and community, providing information and support for those affected, and promoting the advancement of research.



## Ambient Activities Technology

[www.ambientactivity.com](http://www.ambientactivity.com)  
[tammy@ambientactivity.com](mailto:tammy@ambientactivity.com)

### Booth #9

Activity interventions that provide those who live with moderate to severe levels of cognitive impairments opportunities to engage and interact with purposeful activity.



## American Health Care Association and National Center for Assisted Living (AHCA/NCAL)

[www.AHCA.org](http://www.AHCA.org) [www.ncal.org](http://www.ncal.org)  
[lbentley@ahca.org](mailto:lbentley@ahca.org)

The American Health Care Association and National Center for Assisted Living (AHCA/NCAL) represent more than

12,000 non-profit and proprietary skilled nursing centers, assisted living communities, sub-acute centers and homes for individuals with intellectual and developmental disabilities. By delivering solutions for quality care, AHCA/NCAL aims to improve the lives of the millions of frail elders and individuals with disabilities who receive long term or post-acute care in our member organizations each day.

*Concurrent Session Sponsor*



## Ben E. Keith Foods

[www.benekeith.com](http://www.benekeith.com)  
[jdbricht@benekeith.com](mailto:jdbricht@benekeith.com)

### Booth #43

Ben E. Keith Foods distributes quality foodservice products including fresh produce & bread, dairy, frozen foods and meats, grocery, disposables, chemicals, and E&S. Ask us about our program offerings for eMenuManage™ Services, In-Service Training and Nutritional Resource Information.



## The Beryl Institute

[www.theberylinstitute.org](http://www.theberylinstitute.org)  
[natalie.mckay@theberylinstitute.org](mailto:natalie.mckay@theberylinstitute.org)

### Booth #26

The Beryl Institute is the global community of practice dedicated to improving the patient experience through collaboration and shared knowledge. We define patient experience as the sum of all interactions, shaped by an organization's culture, that influence patient perceptions across the continuum of care.





## Colorado Culture Change Coalition

www.coculturechange.org  
info@coculturechange.org

### Booth #20

The Colorado Culture Change Coalition (CCCC) promotes core person-centered values of choice, dignity, respect, self-determination, and purposeful living. We help individuals and organizations develop new ways of thinking, new language, new beliefs, and new behaviors based on a person-centered philosophy of care



ALTERNATIVE®

## The Eden Alternative®

www.edenalt.org  
sgerould@edenalt.org

### Booth #17

Supporting the culture change movement for over 20 years through practical tools, training, and consultation, The Eden Alternative® is a global, non-profit organization focused on creating quality of life for Elders, and their care partners, wherever they may live.



## Eversound

www.eversoundHQ.com  
matt@eversoundhq.com

### Booth #21

Continuing to expand nationally, Eversound helps everyone hear at the perfect volume without the hassle of hearing aids. It's a proven way to improve engagement and participation at group events. Visit [www.eversoundHQ.com](http://www.eversoundHQ.com) to learn more.

*Silent Disco Sponsor*



## Fransen Pittman

www.franserpittman.com  
vhowell@franserpittman.com

### Booth #22

Fransen Pittman is a premier construction company serving communities across Colorado for 24 years. Driven by the desire to be a different breed of builder, we do more than simply build buildings. We create spaces that provide comfort and assistance for your family members.



## Haven Nursing Center

karale.causey@havennursingcenter.com  
Haven Nursing Center is a non-traditional, household model nursing home located in Columbia, Louisiana, dedicated to providing quality care within a life-affirming, caring community.



## Hamilton CapTel

www.hamiltontel.com  
scp@hamiltoncaptel.com  
info@hamiltoncaptel.com

### Booth #27

Hamilton Telecommunications is a diversified communications and technology service provider based in Aurora, Neb. Founded in 1901, Hamilton Telecommunications encompasses eight primary company divisions that allow Hamilton to operate on a local, regional and national basis.



## HealthCare Interactive

www.hcinteractive.com  
cadams@hcinteractive.com

### Booth #4

HealthCare Interactive, Inc. (HCI) is the leading national provider of online,

dementia-care training programs. We are addressing the growing national crisis of memory loss, dementia, and Alzheimer's disease by developing the most innovative set of training products for family members and professional caregivers available in the marketplace today. HCI's educational products are easy to use. Each requires only basic computer or DVD skills and can be used in the privacy of your home or work setting.



## Harloff Company

www.harloff.com  
lcrosby@harloff.com

### Booth #13

Harloff provides a full line of medication furniture to support Culture Change initiatives. Our furniture carts are designed to look like a dresser but provide the security and durability needed for Long Term Care. Our in-room medication cabinet line includes a work space for staff and a slam lock that opens with a key but automatically locks when closed.



## Health Professions Press

www.healthpropress.com  
mmagnus@healthpropress.com

### Booth #32

Health Professions Press is a publisher of professional resources in long-term care, gerontology, and healthcare administration. Titles on display cover topics including leadership, staff training, activity programming, dementia care, and more. Stop by our exhibit for our special conference discount!



## It's Never 2 Late

www.in2l.com  
jyork@in2l.com

### Booth #37

It's Never 2 Late builds engagement systems residents & staff enjoy! Equip staff with the most efficient means of delivering

person centered engagement for memory care, therapy and recreation. Enable residents and families to connect and enjoy life through the unique combination of an unparalleled, vetted content library and extremely intuitive interface. With today's technology you can provide & empower individuals to connect, engage, and enjoy life more fully. iN2L is up and running in almost 3000 communities throughout the US and Canada, changing lives one touch at a time. *Coming of Age Party Sponsor*



### Janska Clothing that Comforts

[www.janska.com](http://www.janska.com)

[jan@janska.com](mailto:jan@janska.com)

#### Booth #50

Janska Clothing That Comforts' social mission is to impact the lives of others by restoring dignity when dressing is no longer simple and providing a profound feeling of comfort during challenging times of life.



### Joy for All Companion Pets

[www.joyforall.hasbro.com](http://www.joyforall.hasbro.com)

[tom@agelessinnovation.com](mailto:tom@agelessinnovation.com)

#### Booth #33

Joy for All Companion Pets are designed to bring comfort, companionship and fun to elder loved ones. With realistic fur and pet-like sounds — and sensors that respond to petting and hugs with familiar pet-like actions — Companion Pets deliver a soothing, joyful experience that inspire smiles, laughter and fond memories for people of all ages.



*Kentucky Coalition for Person Centered Care*

### Kentucky Coalition for Person Centered Care

[www.kcpcc.org](http://www.kcpcc.org)

[mhaynes@nazhome.org](mailto:mhaynes@nazhome.org)

#### Booth #30

The Kentucky Coalition for Person Centered Care is a recently established

organization consisting of a group of stakeholders interested in pursuing the implementation and progression of Person Centered Care throughout the long term care profession for all Kentuckians.



### LifeBio

[www.lifebio.com](http://www.lifebio.com)

[bsanders@lifebio.com](mailto:bsanders@lifebio.com) [saskia@lifebio.com](mailto:saskia@lifebio.com)

#### Booth #24

LifeBio captures life stories to exceed person-centered care goals. LifeBio's online system and army of writers build Life Story Books, Snapshots, and Action Plans for each unique person. Approaches for memory care include Phone Interviews of family members to know more.



### LifeShare Technologies

[www.lifesharetech.com](http://www.lifesharetech.com)

[cindy.vondenkamp@lifesharetech.com](mailto:cindy.vondenkamp@lifesharetech.com)

#### Booth #34

LifeShare keeps families, residents and staff informed, connected and engaged through visual messaging on any TV screen supporting calendars, therapeutic music, games, automated reminders, faith programming, free mobile app and more. Affordable, easy, super useful technology.....what a concept!



### Eli Lilly

[www.lilly.com](http://www.lilly.com)

[Turpin\\_kathleen\\_j@lilly.com](mailto:Turpin_kathleen_j@lilly.com)

#### Booth #14

Lilly is a global healthcare leader that unites caring with discovery to make life better for people around the world. We were founded more than a century ago by a man committed to creating high-quality medicines that meet real needs, and today we remain true to that mission in all our work. Across the globe, Lilly employees work to discover and bring

life-changing medicines to those who need them, improve the understanding and management of disease, and give back to communities through philanthropy and volunteerism. To learn more about Lilly, please visit us at [www.lilly.com](http://www.lilly.com) and <http://newsroom.lilly.com/social-channels>.



### Linet Americas

[www.linetamericas.com](http://www.linetamericas.com)

[joel.clark@linetamericas.com](mailto:joel.clark@linetamericas.com)

#### Booth #45

LINET Americas is headquartered in Charlotte, North Carolina and provides sales and service to over 500 customers across the United States and Canada. With more than 15,000 beds installed coast-to-coast, it is LINET Americas' goal to help improve the cost and quality of healthcare by providing practical solutions to our customers.



### MemoryWell

[www.memorywell.com](http://www.memorywell.com)

[jay@memorywell.com](mailto:jay@memorywell.com)

#### Booth #44

MemoryWell is a digital platform for elder storytelling. Our network of more than 500 professional writers works with families, senior living communities and home care providers to replace burdensome intake questionnaires with brief, intimate stories. MemoryWell's portraits build empathy and are poignant keepsakes for families.

*Life Enrichment Track Sponsor*





## Metropolitan State University of Denver

www.msudenver.edu/mha  
csciaca@msudenver.edu

### Booth #12

Our program is designed to develop health care leaders for a rapidly changing world. Metropolitan State University of Denver Master of Health Administration (MHA), prepares students for a challenging and rewarding career in health care.

## mobileserve

### MobileServe

www.mobileserve.com  
ben@mobileserve.com

### Booth #39

MobileServe helps organizations to easily manage and engage volunteers. From sourcing and scheduling to reminding, tracking, thanking, and recognizing, MobileServe's mobile and web-based platform automates the logistics so you can focus on the people. MobileServe's easy photo-platform and social media integrations turns volunteers into ambassadors.



### Music & Memory

www.musicandmemory.org  
dcohen@musicandmemory.org

### Booth #46

Music & Memory advocates for the use of personalized music to improve the quality of life for individuals facing a variety of cognitive and physical situations, especially those with dementia. By providing education, training and support to a network of long-term care organizations, hospitals, hospices and home care programs, we aim to make this form of personalized, therapeutic music a gold standard of care in all 67,000 U.S. health care settings.



## National Association of Activity Professionals

www.naap.info  
office@naap.info

### Booth #5

The National Association of Activity Professionals provides education, advocacy, and support to Activity Professionals working in various geriatric settings throughout the United States and Internationally.

National Association of Activity Professionals



CREDENTIALING CENTER

## National Association of Activity Professionals Credentialing Center

www.naapcc.net  
naapcc.office@gmail.com

### Booth #42

The NAAP Credentialing Center was established for the exclusive purpose of granting a National Board Certification for Activity Professionals who meet our standards. No class or course work is required. We are recognized by CMS under F-tags 658 & 680.



## National Consumer Voice for Quality Long-Term Care

www.theconsumervoice.org  
ckohler@theconsumervoice.org

### Booth #40

Consumer Voice is the leading national voice representing consumers in issues related to long-term care, helping to ensure that consumers are empowered to advocate for themselves. We are a primary source of information and tools for consumers, families, caregivers, advocates and ombudsmen to help ensure quality care for the individual.



PERSON CENTRED UNIVERSE

## Person Centred Universe, Inc.

www.personcentreduniverse.com  
aking@personcentreduniverse.com

### Booth #35

Person Centred Universe (PCU) is a company that has a simple vision — we see a better world for those affected by Dementia. Since 2013, PCU has been standing by the belief that quality person-centred dementia care and support for care partners is attainable when given access to education and resources that encourage empathy, respect and leadership. By developing and nurturing leaders, we support those working with individuals living with dementia to understand and appreciate their client's unique journey, and how care partners can support those living with dementia to live dignified lives.



Quality Care THROUGH Quality Jobs

### PHI

www.PHInational.org  
smisiorski@phinational.org

PHI works to ensure quality care for older adults and people living with disabilities by creating quality jobs for direct care workers. We believe that caring committed relationships between direct care workers and their clients are at the heart of quality care. We offer all the tools necessary to provide quality jobs for workers and quality care for clients: training for direct care workers, consulting for employers, and research for policy makers.

Workforce Track Sponsor



### RCare, Inc.

www.rcareinc.com  
mikea@rcareinc.com

### Booth #25

RCare is a global provider of the most advanced UL 1069-listed nurse call and monitoring technology for senior housing



campuses of all sizes. RCare builds individualized, flexible and seamless solutions to enhance caregiving and resident quality of life.



### Rockport Healthcare Services

[www.ahearttoserve.org](http://www.ahearttoserve.org)

[MLysobey@rockporthc.com](mailto:MLysobey@rockporthc.com)

#### Booth #29

Rockport Healthcare Services recognizes that person-centered care includes honoring the individual's purpose in life. People in care communities are more capable than commonly believed. Partnering with Pioneer Network, the Community Commitment Award celebrates examples of these amazing acts of service.



### Schlegel Villages, Inc.

[www.schlegelvillages.com](http://www.schlegelvillages.com)

[jessica.luhkim@schlegelvillages.com](mailto:jessica.luhkim@schlegelvillages.com)

Canadian family owned and operated, Schlegel Villages offers quality long-term care and retirement living across south-western Ontario. Come and discover why It Takes a Village to Care!

*Leadership Track Sponsor*



### Schlegel-UW Research Institute for Aging

[www.the-ria.ca/walkwithme](http://www.the-ria.ca/walkwithme)

[hilary.dunn@uwaterloo.ca](mailto:hilary.dunn@uwaterloo.ca)

#### Booth #38

Walk with Me is a national movement aimed at changing the culture of aging in Canada. Older adults, care partners, educators, policy makers, students and researchers from all over the country collaborate and learn with and from each other about how to enhance the journey of aging across the continuum of care and community living.



### Select Rehabilitation, LLC

[www.selectrehab.com](http://www.selectrehab.com)

[swisnowski@selectrehab.com](mailto:swisnowski@selectrehab.com)

#### Booth #1

Select Rehabilitation provides comprehensive physical, occupational and speech therapy services to patients in hundreds of sites across 32 states, and also partners with clients to provide expertise in regulatory and reimbursement issues. Emphasis is placed on patient-focused, outcome-driven services allowing patients to successfully transition and remain in their discharge environment.

*Tech Experience Sponsor*



### SWBR Architects

[www.swbr.com](http://www.swbr.com)

[kfederico@swbr.com](mailto:kfederico@swbr.com)

#### Booth #36

SWBR has offices in Syracuse and Rochester, NY providing design for independent, assisted, skilled nursing and Green House projects for public and private clients.



### QUALITY OF LIFE SERVICES

#### Sodexo

[www.sodexo.com](http://www.sodexo.com)

[todd.andrews@sodexo.com](mailto:todd.andrews@sodexo.com)

Sodexo is the world leader in providing Quality of Life Services to the field of senior living, leveraging our expertise to positively impact your residents health and wellness, safety, nutrition and overall experience.

*Leadership Forum Sponsor*



### TZMO USA, Inc./SENI

[www.tzmousa.com](http://www.tzmousa.com)

[mihaela.grigore@tzmousa.com](mailto:mihaela.grigore@tzmousa.com)

#### Booth #31

Seni supports your person-centered

activities with a full line of vapor preamble incontinence products. From light incontinence pads to briefs for severe incontinence and night time protection Seni covers all type of products someone with incontinence may need. Contact us and learn how other Pioneers implemented Seni continence program in their homes. Better nights and overall health for people you care for thanks to Seni Night time products.



— WINNING THE MATURE MARKET™ —

### Varsity

[www.varsitybranding.com](http://www.varsitybranding.com)

[wlangley@varsitybranding.com](mailto:wlangley@varsitybranding.com)

#### Booth #41

Varsity is a full-service boutique firm focused on winning the mature market. We're innovators, not imitators. Focused, not fragmented. The only team to offer you a 360-degree view of your business and up-close insights. Our mature market specialists have expertise in marketing, sales, PR, creative, interactive, digital, media and operational performance.



### Vivage Senior Living

[www.vivage.com](http://www.vivage.com)

[swarnsholz@vivage.com](mailto:swarnsholz@vivage.com)

Nationally-recognized long-term and post-acute management and consulting company dedicated to a person-directed model of care for elders of all ages in our communities.

*Concurrent Sessions Sponsor*



### Wish of a Lifetime

[www.wishofalifetime.org](http://www.wishofalifetime.org)

[tom@wishofalifetime.org](mailto:tom@wishofalifetime.org)

#### Booth #6

The mission of WOL (a nonprofit) is to "shift the way society views and values our oldest generations by fulfilling seniors™ dreams and sharing their stories to inspire those of all ages."

# Exhibitor & Sponsor Gallery

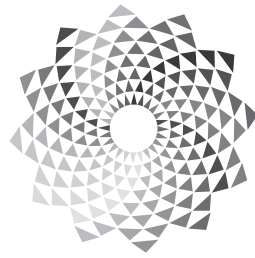

Pioneer Network

# Pioneering a New Culture of Aging Conference

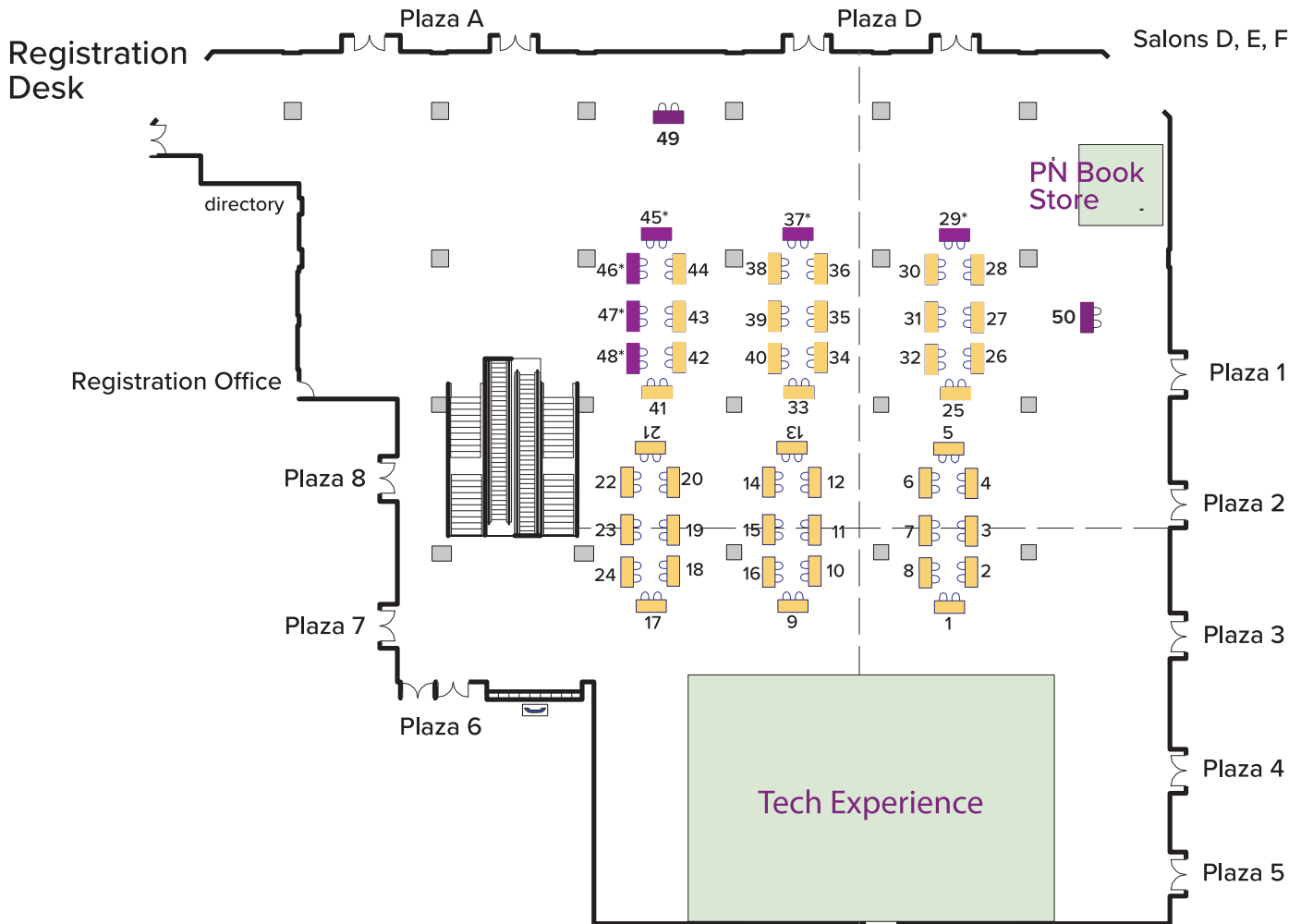

ORGANIZATION	BOOTH #
AGE-u-cate Training Institute	28
Alzheimer's Association	49
Ambient Activities Technology	9
Ben E. Keith Foods	43
The Beryl Institute	26
Colorado Culture Change Coalition	20
The Eden Alternative®	17
Eversound	21
Fransen Pittman	22
Hamilton CapTel	27
HealthCare Interactive	4
Harloff Company	13
Health Professions Press	32
It's Never 2 Late	37
Janska Clothing that Comforts	50

ORGANIZATION	BOOTH #
Joy for All Companion Pets	33
Kentucky Coalition for Person Centered Care	30
LifeBio	24
LifeShare Technologies	34
Eli Lilly	14
Linnet Americas	45
MemoryWell	44
Metropolitan State University of Denver	12
MobileServe	39
Music & Memory	46
National Association of Activity Professionals	5

ORGANIZATION	BOOTH #
National Association of Activity Professionals Credentialing Center	42
National Consumer Voice for Quality Long-Term Care	40
Person Centred Universe, Inc.	35
RCare, Inc.	25
Rockport Healthcare Services	29
Schlegel-UW Research Institute for Aging	38
Select Rehabilitation, LLC	1
SWBR Architects	36
TZMO USA, Inc./SENI	31
Varsity	41
Wish of a Lifetime	6



## Make the Most of Your Conference Experience

It all began 21 years ago when the first Pioneers came together to share their common vision and start a movement. Today, the Pioneer Network Conference remains the place to “meet your people”, your peers and colleagues from around the country — and even from around the world. Kindred spirits who come together in one place for the purpose of pioneering a new culture of aging and advancing the culture change movement.

### HERE ARE SOME HELPFUL TIPS:

**1 Connect with the Network!** What do our attendees enjoy almost as much as our sessions? Networking with like-minded people from across the country and around the world. Don't be shy, introduce yourself!

**2 Can't remember someone's name?** Yes, we know that names, our identities, are important, but we all forget names. Don't let this be the barrier to starting a new relationship or rekindling an old one. Chances are, they can't remember your name, either!

**3 Take time to visit our Sponsors and Exhibitors!** They have wonderful information to share with you. Make sure you share your business card with them. Be sure to look for the **Partners in Pioneering** logo, identifying exhibitors who are part of the program so you can earn CEUs.



**4 Stay comfortable—bring a sweater or jacket or the Pioneer Network travel blanket that you purchased at the conference store** to the meeting rooms and events. One person is always freezing and the other is burning up, so come wearing layers.

**5 Use the Pioneer Network Conference APP.** It has the schedule, map, handouts and more. Come to the **Sunday Welcome Session** to learn how to make the most of it or stop by the registration desk if you have questions! (You can find directions for downloading the App in the General Conference Information section on page 12.)

**6 Take advantage of the many resources you will find in the Exhibitor and Sponsor Gallery.** Exhibitors, Sponsors, Book Store, Registration and more. Check out the hours on conference signage and on the Pioneer Network 2018 App (Attendify).

**7 We know that sometimes no matter how hard we try, things don't always go as planned.** If you identify something that isn't as it should be with the conference, don't just tell your neighbor, **tell us.** Go to the Registration Desk and they will find the right person to help you. Conference staff and dozens of volunteers stand ready to do everything we can to make this a person-centered conference experience for you.

**8 If you came with a team from your workplace, split up,** and go to different sessions. You will have more information to share with your organization when you go home!

**9 Stop by the Pioneer Network Book Store** and pick up some inspirational and educational resources to take home.

**10 Share your kind heart and open mind.** We may have a lot of work yet to do, but we have accomplished much and it's time to take time to celebrate, so **HAVE FUN!**

# General Conference Information



## Pioneer Network App

Access the Pioneer Network Conference Mobile app by downloading Attendify in the app store and searching for "Pioneer Network Conference" or directly at <https://attendify.com/app/wi0zmk> for iOS and Android phones.

For those without an android or iOS phone, download the web app at <http://wi0zmk.m.attendify.com/app/webview/9W1sWN4llplud1OXx>

This is the place to go to get up-to date information on conference events and all the latest happenings. You'll find the conference schedule, locations of all events, **session descriptions and guide biographies and a place to rate the sessions and Guides.** You can also create a personal schedule. The App is available for download on your smart phone or tablet through Apple App Store and Google Play Store. Assistance is available at the registration desk or check out the tutorial on the Pioneer Network website, [pioneernetwork.net](http://pioneernetwork.net)

## Accessibility

Pioneer Network is committed to providing equal access for all attendees and their guests. Please see our Registration Desk if you have any questions.

## Registration Hours

Sunday, 11:00 am – 6:30 pm  
Monday, 7:00 am – 5:00 pm  
Tuesday, 7:00 am – 6:00 pm  
Wednesday, 7:30 am – 4:30 pm

## Name Badges

Your registration name badge is your admission ticket to all sessions. Our badges are designed to help create community when we can all see each other's name and where we are from! Please wear your badge at all times. (NOTE: Meals, Site Visits and Workshop Intensives require the tickets you received at registration.)

## Rings. Whistles. Beeps.

Please ensure that all ringers/alarms are turned off or set to vibrate during all sessions out of respect for the session Guides and your fellow participants.

## Concurrent Sessions

Sessions are planned to begin and end on time and we have made every effort to ensure that each room has seating to accommodate all attendees. Though we don't anticipate it, a session could fill and we cannot add more chairs because of fire codes. Signs at session entrances will identify if a session is full. There will be a Room Monitor in each session. Please let this person know if you need anything.

## Technology

All Denver Downtown Sheraton hotel guests booked within the Pioneer Network room block will have complimentary standard wireless internet access in their guestrooms. Wi-Fi is not available in the exhibit area or session rooms. If you need additional Wi-Fi support as an Exhibitor, Sponsor or session Guide, go to the Registration Desk for information.

## Handouts

Some Workshop Intensives may have handouts in their rooms. All concurrent Education Session handouts and Take-Away resources submitted are available on our website and through the Pioneer Network 2018 App during and after the conference. We know how difficult it is to choose between sessions, so this way you can access all the Education Session handouts.

# Conference Features

## Pioneer Network Book Store Exhibitor / Sponsor Gallery

Be sure to visit the Pioneer Network Book Store to check out the latest resources for your culture change journey including books, DVDs, workbooks and toolkits. Many of the authors will be on hand at the conference serving as Guides, providing you with the opportunity to talk to them in person about their books or other topics. There are also Pioneer Network branded travel blankets

to keep you warm in the air-conditioned hotel or on the airplane and T-shirts and culture change themed buttons and bumper stickers to bring home with you to spread the word.

**Meet the Authors** at Special Book Signing opportunities taking place during Exhibitor/ Sponsor Gallery hours on Monday and Tuesday and during the Pioneer Network Coming of Age Networking Reception on Monday evening.



## Getting Around

We know as Pioneers, you thrive on adventure, and many of you will want to explore the many shops and restaurants in the area. We believe you will be able to find everything you are looking for on the 16th Street Mall — right outside the hotel. Maps and additional information about places to go are available on the Pioneer Network 2018 App, at the registration desk, or you can check with the hotel Concierge.

## Watch Your Language!

Is your language institutional or person-centered? Make a commitment to do your part to change the culture of aging through the use of person-centered language. If you haven't done so already, check out the **Commitment to Person-Centered Language** available on the Pioneer Network website as well as on the Pioneer Network 2018 App, and make a personal commitment to using person-centered language while you're at the conference and bring the challenge home to your team when you return to carry on your work!

## Photo/Video Release

We use photographs from conferences in our printed materials and on our website. By virtue of your attendance, Pioneer Network reserves the right to use your likeness in such materials. This also includes sessions where there will be live videotaping.

## Continuing Education Credits

Provisions for Continuing Education (CE) credits are available for a separate fee of \$30.00 for each license type. If not already paid in advance, visit the registration desk to add this.

For nursing home administrators, application has been made with the National Continuing Education Review Service (NCERS) of the National Association of Long Term Care Administrator Boards for 30.5 hours.

For nurses, application has been made with the Nursing Continuing Education Committee at the Maryland Nurses Association, an accredited approver by the American Nurses Credentialing Center's Commission on Accreditation for 30.5 hours.

For social workers, application has been made with the National Association of Social Workers for 30.5 Social Work continuing education contact hours.

For activity professionals, application has been made with the National Certification Council for Activity Professionals for 30.5 clock hours of continuing education.

For dietitians, application has been made with The Commission on Dietetic Registration — the credentialing agency for the Academy of Nutrition & Dietetics for 30.5 CPEUs for CPE levels 1, 2 and 3.

## Using Your Exhibit Hall Passport to Obtain CEUs

(Included in your Conference registration materials)

### Partners in Pioneering: Exploring New Options

- Visit at least eight exhibitors participating Partners in Pioneering and engage in a conversation about their product and how it supports Person-Centered Care (PCC)
- Get your passport validated
- Answer the questions on the Quiz provided with your passport.

### Tech Experience

- Take the Tech Experience Tour.
- Get your passport validated

### Dementia Live

- Experience Dementia Live, including the post tour de-briefing.
- Get your passport validated

### Poster Sessions

- Participate in the guided tour of the Poster Sessions with your Guide, Margie McLaughlin.
- Get your passport validated

***Turn in your Passport and completed Quiz to Registration with your CEU materials at the end of the conference.***



## Pioneer Network Quilts

### Exhibitor and Sponsor Gallery and in various locations around our host hotel

21 years ago, a quilt square was chosen as the symbol of the Pioneer Network, depicting the warmth and homey feeling that a quilt conveys. As the first conference was being planned, it only seemed natural to have a quilt as a part of the conference, further representing the diversity and networking required to create

something special and unique. This tradition has been carried through at every conference since, and so in celebration of our 21st birthday, we have brought all the quilts from prior years to display. Don't forget to sign this year's quilt, so that years from now, you can come back and remember and know that you responded to the call in 2018 to be a part of "pioneering a new culture of aging!"

# Conference Special Sessions

## SUNDAY, AUGUST 12

### Pioneer Network and the Ombudsman Program: Partners on the Journey

1:15am – 4:30pm

Plaza Ballroom A/D

(Additional \$25.00 Fee)

*“All elders are entitled to self-determination wherever they live”* — it’s a Pioneer Network value, and who better understands the meaning behind this value than long-term care ombudsmen! Pioneer Network is pleased to present a session at this year’s conference focusing on the connection between the work of the culture change movement and the Ombudsman Program. In this interactive session, Penny Cook, President & CEO of Pioneer Network, will begin by exploring with attendees just what that connection is. Guides will continue the conversation by reviewing the new Ombudsman Guidance and residents’ rights. Seeing the connection is one thing, but making the connection requires resources and tools, and that’s just what will be shared — ideas and programs that Pioneer Network and others have to offer to Ombudsmen which can be shared with communities to help them on their journey. And of course, no session at a Pioneer Network Conference would be complete without a few stories, and so in this session, you will hear stories of what is happening across the country and leave with the knowledge that we can do things differently...that residents’ rights can be realized in a way that brings quality of life to elders.

Guides:

**Penny Cook**, President & CEO, Pioneer Network

**Katie Kohler**, Program and Outreach Specialist, Consumer Voice

**Julie Wilson**, Facility Advisory Nurse II, Missouri Department of Health and Senior Services

**Eileen Bennett**, Montgomery County Maryland LTC Ombudsman Program

**Tessa Burton**, Office of the Ohio LTC Ombudsman

**Angie McAllister**, Director of Cultural Transformation, Hometown Signature HealthCARE

### Welcome:

### Let the Networking Begin!

5:00pm – 6:30pm

Plaza Ballroom B/C/E/F

Join us for a chance to start your 2018 Pioneer Network conference experience by getting to know your fellow Pioneers as we do the *traditional Roll Call of States, Provinces and Nations*. Our goal is that this year’s conference experience will be your best ever, and so **Jill Vitale-Aussem**, President & CEO of The Eden Alternative®, will be sharing some fun and engaging ways to get the most out of your conference experience. But we know you’re also looking for some details, so you will have a chance to learn more about the many conference events that will be happening over the next three days. And there’s more! Every conference experience is individualized, and so to help you create your own person-centered conference plan, there will be a demonstration on how to use the Pioneer Network App, a tool that can serve as your guide as you navigate and plan your days in Denver. All that, plus a few surprises...because what better way to start a Pioneer Network conference than living the Pioneer principle, that *relationship is the fundamental building block of a transformed culture!*

## MONDAY, AUGUST 13

### Morning General Session and Breakfast Creating Community: It Takes a Team

8:00am – 10:15am

Plaza Ballroom B/C/E/F

Pioneer Network’s Values and Principles tell us that *Community is the Antidote*

*to Institutionalization*, so what better theme for our opening general session! Join us for the official convening of the Pioneers as you hear from **Penny Cook**, Pioneer Network’s President and CEO, about the state of the movement. Then join us as we explore ways that community is being created by Pioneering teams throughout the country and beyond. Hear from the leaders of two organizations who have taken community engagement to a new level, Masterpiece Living founder and author of the book *Live Long, Die Short*, **Dr. Roger Landry, MD**, and Rockport HealthCare Services CEO, **Dr. Michael Wasserman, MD, CMD**. What better way to end than by celebrating the winners of the **First Annual Community Commitment Awards**. Hear from the award-winning teams about the projects that their residents are leading that are providing meaning and purpose in their lives and in the lives of those in the greater community.

### Pioneer Network, Celebrating 21 Years and Coming of Age! Networking Reception

Monday, August 13

4:30pm – 6:30pm

Sponsor / Exhibitor Gallery

What can be more fun than a chance to network with our exhibitors, sponsors and your fellow Pioneers, spending time together *responding to spirit, as well as mind and body!*

Come celebrate with our Sponsors and Exhibitors and thank them for their generous support. Visit with them to learn about innovative services and products, share your needs, challenges, and ideas for future products and services to help you on your journey, enjoy appetizers and drinks, and perhaps you’ll even be the winner of one of our great giveaways.

But there’s more, as this reception promises that it won’t be your typical event. Do you remember your 21st birthday? All of a sudden, you’re an adult! This networking event/party will take you back in time to celebrate Pioneer Network’s 21st birthday. We’ll go back 21 years ago, to 1997, and relive the music and camaraderie of those days gone by.

## Coming of Age Party!

Monday, August 13

7:30pm – ???

Coyote Ugly

Pioneer Network is coming of age and that means we are old enough to party the night away! So, before you leave the reception, you'll want to get your Fake ID — you'll need it to get into the party hosted by It's Never 2 Late at Coyote Ugly, located just a short walk away on the 16th Street Mall. We promise a great time with live music and some special treats, including a chance to experience silent disco, hosted by the team at Eversound! Not sure what that is — well, we guess you'll have to come to find out!

In addition, iN2L is offering a \$500 Prize for whoever has the **best costume/look representing 1997**. This is your chance to let it all hang out, laugh and reminisce. It's culture change at its finest!

## TUESDAY, AUGUST 14

### Afternoon General Session

#### Are You Ready for the Future?

3:00pm – 5:00pm

Plaza Ballroom B/C/E/F

The future is coming, and while we as Pioneers have been working for change for over 20 years now, we know that the future holds many challenges that we need to identify and then figure out how to meet. We can start by asking ourselves if we are ready for the future... but more importantly, we need to GET READY for the future!

As we all come together as a group for the last time, we have some very special speakers who will be sharing messages to inspire, motivate and teach.

We will begin by hearing from some wise leaders. Individuals who have led their organizations through change, creating and sustaining cultures where the Pioneer Network mission, values and principles are lived out every day. These leaders met earlier at the conference, bringing their shared wisdom and experience as they

discussed some of the secrets to their success. Now we have the opportunity to hear from these wise leaders as they share some of those secrets and give us a little advice to take home on how we can help spread the message to other Executive Leaders who can help take our movement into the future.

While we know we need to prepare our organizations for change, we also know that being ready for the future requires a personal journey for each one of us to take, as well as one in which we support and grow current and future care partners.

And so, as we end the session, we are pleased to welcome a fellow Pioneer, Emmy Award winner **Leeza Gibbons**. Perhaps you know Leeza from her time as a host of *Entertainment Tonight*, or as a winner of *Celebrity Apprentice*, but did you know that Leeza has a connection to us? Caregiving and passion. After caring for her mother as she struggled with Alzheimer's disease, Leeza started the **Leeza Gibbons Memory Foundation** and its signature program, 'Leeza's Care Connections,' an organization whose mission is to "prepare caregivers for an ever-changing life by providing innovative self-care and wellness programs and resources."

We are confident that you will leave this session feeling renewed in the belief that **each person can and does make a difference!**



## Look Good, Feel Good

5:30pm – 6:00pm

Plaza Ballroom A/D

What happens when the simple act of dressing is no longer simple? This is a question that Jan Erickson has been exploring for the last 15 years. The important truth she's uncovered is: Clothing does matter, and how we present to the world significantly impacts our sense of personhood, as well as how we are perceived by others. In this person-centered fashion show presentation, you will be introduced to **Janska Clothing That Comforts** and Jan's mission to serve women at all stages of life with garments that make them look good and feel good. Members of Denver's elder community will model **Clothing That Comforts**, as Jan shares her research and discoveries surrounding the important topic of dressing with dignity, and finds new meaning in the Pioneer Network value, *put person before task*.

### Continuing the Conversation: What Does It Take to Move the Mountain?

6:00 pm – 7:30 pm

Plaza Ballroom A/D

At the 2017 Pioneer Network Conference, we had two special sessions in which participants explored the future with Elders and their fellow providers. That was the start of the conversation. Join our session moderators, KaraLe Causey, Board Chair, Pioneer Network and Megan Hannan, Executive Leader with Action Pact, along with a panel of Elders, as we continue the conversation and the exploration of what it will take for us to "move the mountain" and make the Pioneer Network's vision of creating a culture of aging that is Life-Affirming, Satisfying, Humane and Meaningful a reality for all of us and reminding us that **culture change and transformation are not destinations but a journey, always a work in progress.**



# Sponsor / Exhibitor Gallery

Monday, August 13

12:15 pm – 2:30 pm & 4:30 pm – 6:30 pm

Tuesday, August 14

11:30 am - 1:00 pm

Pioneer Network believes that building relationships between the care partners who are providing services to elders and the many organizations who create new and innovative tools and programs to support those care partners in their work are vital if we are to meet the demands of the future. We encourage you to take the opportunity to learn from exhibitors and sponsors about the different products and programs they offer and how they support person-centered care practices and are helping to change the culture of aging. Look for the logo displayed at the booths of those exhibitors who are participating in the Partners in Pioneering Program, and then be sure to have the Passport that was included with your registration materials validated so that you can obtain CEUs.



## Tech Experience

Senior living and technology has historically had a connotation of clinical tools such as medical records, MDS software, etc. That obviously has relevance, but there are a multitude of technologies emerging that will enhance the lives of elders and make life fun for people of all ages! Pioneer Network is delighted to present an interactive technology experience that will change your perception of aging, and of senior living. Virtual reality, robots, immersive sensors, wearables and voice activation are just some of what you will see and feel at the conference — new technologies developed by innovators and dreamers who understand that new and different can be good — that **risk taking is a normal part of life**. We don't want to tell you any more than that for now, you'll have to attend to find out. Seeing is believing!

## Dementia Live Experience

Dementia Live is an experience that immerses participants into what life might be like living with cognitive impairment and sensory change.

Utilizing specialized gear that simulates dementia specific changes that include altered eyesight, hearing and tactile sensation, this safe experience is a powerful and effective tool to strengthen care partner's understanding of and empathy for their residents. Gaining a first-hand understanding of anxiety, isolation, frustration, confusion, and more, Dementia Live uniquely walks participants from the "AHA" moment to empowering caregivers with tools to improve communication, care processes, and the environment as they gain insight to help them as they get to **know each person** who is living with dementia.

## Photo Gallery

As a special treat this year, we invite you to tour the Photo Gallery, located in the Sponsor and Exhibitor Gallery, and enjoy the beautiful and inspiring photos taken by **Jennifer Dill**, Director of Life Enrichment, depicting the joy of community life experienced by the Elders at Chelsea Place Assisted Living. You will see come alive in these photos the joy experienced when we practice the Pioneer value that **all elders are entitled to self-determination wherever they live**.

## Lunch & Networking

Monday August 13

12:15 pm - 1:15 pm

Plaza Ballroom A/D

Join your fellow Pioneers for some facilitated table discussion on person-centered topics that are Hot! Pick up your box lunch and bring it to the Plaza Ballroom where you can choose the topic you want to discuss and share lively conversation over lunch as you **promote the growth and development of all**. All that, and still plenty of time to visit with our Exhibitors & Sponsors before catching your afternoon sessions!

## Learning Circles

Monday August 13

1:30 pm - 2:30 pm

Plaza Court 2, 3, 4, 5 and Governor's Square 9

As Pioneers, we are always looking for new and innovative ways to design care and services to support resident choice and autonomy — and make life better for all care partners. Sometimes, be it real or perceived, rules and regulations get in our way. Join your fellow pioneers and engage in a lively learning circle as you share your answer to the following question: *"If there was one "rule" or "generally accepted practice" that you could change or eliminate to help you do what you WANT to do to support elders or other care partners, what would it be?"* Together let's **practice self-examination, searching for new creativity and opportunities for doing better**.

## Gallery Walk:

### A Guided Tour Through the 2018 Poster Sessions

Tuesday August 14

12:00 pm - 1:00 pm

Meet at the Registration Desk

Have you ever gone to an art museum and joined in a tour with a guide who helped you to gain the most from your gallery experience? Well, this is the very experience that we are replicating at the Gallery Walk. Take some time to learn what others have done to support a culture of person-centered care. Discover the innovations described by the Poster Session experts. Ask questions and learn from these courageous, national experts.

Facilitated by Marguerite McLaughlin, join with colleagues, friends, and experts in learning the ideas and innovations of the 2018 Poster Session experts. What a great way to **promote growth and development for all**.



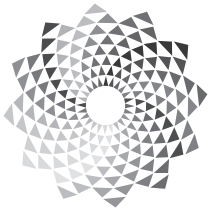

Pioneer Network

# Pioneering a New Culture of Aging Conference

## SCHEDULE AT A GLANCE

### SUNDAY, AUGUST 12, 2018

11:00 am – 6:30 pm	Registration Open
1:00 pm – 4:30 pm	Site Visit: Chelsea Place Memory Care in Aurora
1:15 pm – 4:30 pm	Special Session: Pioneer Network and the Ombudsman Program: Partners on the Journey; Plaza Ballroom A/D
1:30 pm – 4:30 pm	Site Visit: Amberwood Court, Brookshire House and Rowan Community; Meet at Registration
5:00 pm – 6:30 pm	Welcome: Let the Networking Begin; Plaza Ballroom B/C/E/F

### MONDAY, AUGUST 13, 2018

7:00 am – 5:00 pm	Registration Open
8:00 am – 10:15 am	General Session: Creating Community — It Takes a Team; Plaza Ballroom B/C/E/F
10:45 am – 12:15 pm	Concurrent Session A
12:15 pm – 2:30 pm	Exhibit Hall (Box Lunch available until 1:00 pm)
1:30 pm – 2:30 pm	Learning Circles; Plaza Court 2, 3, 4 & 5, Governor's Square 9
2:30 pm – 4:30 pm	Concurrent Session B
4:30 pm – 6:30 pm	Reception: Celebrating 21 Years and Coming of Age; Exhibit Hall
7:30-?	Coming of Age Party; Coyote Ugly

### TUESDAY, AUGUST 14, 2018

7:00 am – 6:00 pm	Registration Open
8:00 am – 9:30 am	Concurrent Session C
10:00 am – 11:30 am	Concurrent Session D
11:30 am – 1:00 pm	Tech Experience, Dementia Live Experience, Photo Gallery; Exhibit Hall (Box lunch available until 12:15 pm)
12:00 pm – 1:00 pm	Welcome to the Gallery Walk – Poster Session Tour; Meet at Registration
1:00 pm – 2:30 pm	Concurrent Session E
3:00 pm – 5:00 pm	General Session: Are You Ready for the Future?; Plaza Ballroom B/C/E/F
5:30 pm – 6:00 pm	Look Good, Feel Good Fashion Show; Plaza Ballroom A/D
6:00 pm – 7:30 pm	Continuing the Conversation: What Does It Take to Move a Mountain?; Plaza Ballroom A/D

### WEDNESDAY, AUGUST 15, 2018

7:30 am – 4:30 pm	Registration Open
8:00 am – 4:30 pm	All Day Intensives and Site Visits
8:00 am – 11:45	Half Day Intensives AM
12:45 pm – 4:30 pm	Half Day Intensives PM

\*schedule is subject to change

# Concurrent Sessions

Pioneer Network's 2018 Conference offers 90-minute concurrent Education Sessions during five different time periods. These are facilitated by a diverse group of expert Guides (faculty), including professors, consultants, regulators, CEOs, direct care workers and those who are "walking the walk" every single day. Whether you have been working in culture change for many years, or are new to the journey, we guarantee that you will find something to stimulate your interest. Session space is on a first-come, first-seated basis. **For session descriptions and guide biographies, go to the Pioneer Network Conference App** (see page 12).

**Monday, August 13, 2018**

**Concurrent Session A: 10:30AM – 12:00PM**



Plaza Ballroom A

## **A1** Transforming the Looming Workforce Crisis into an Opportunity for Career Enhancement

Guides: **Susan Ryan**, Senior Director, The Green House Project

**Lisa Czolowski**, CEO, Hover Community

**Jennifer Vecchi**, Principal, Veechi & Associates



Plaza Ballroom D

## **A2** The Cutting Edge of Dementia Care Culture Change — Technology Supported Engagement, Rehabilitation, and Research for Those Living with Dementia

Guides: **Christopher Krause**, Director of Rehabilitation, It's Never 2 Late

**Carrie Chiusano**, Executive Director, Dementia Care Center of Excellence, Presbyterian Senior Care

Plaza Ballroom B/E

## **A3** Dining at Home — My Way, Your Way, Our Way

Guide: **Linda Bump**, Registered Dietitian/Administrator, Action Pact

Governor's Square 10

## **A4** Person-Centered Care and Parkinson's Disease

Guides: **Natalie Macaro**, Director of Adult Day Programs, Parker

**Lori Morell**, Sr. Manager of Health & Wellness, Parker

**Tanvi Desai**, Director of Rehabilitation, Parker

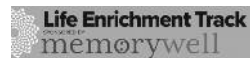

Governor's Square 11

## **A5** Chair Chi: Tai Chi in a Chair for Movement Impaired Populations

Guide: **Patrick Griffith**, Founder, Chair Chi

Governor's Square 12

## **A6** Healing Dementia

Guide: **Kyrie Carpenter**, Integral Coach, Kyrieosity

Governor's Square 14

## **A7** Hiring Staff, It's The Elders Role!

Guide: **Becky Haldorson**, Administrator, Sunny Hill Nursing Home of Will County



Governor's Square 15

## **A8** Can Hospitality Create Home?

Guide: **Jill Vitale-Aussem**, President & CEO, The Eden Alternative

Governor's Square 16

## **A9** Emergency Preparedness — The Person-Centered Way

Guides: **Jeffrey Ahl**, Owner and Principal

**DeAnn Larson**, Project Coordinator, arCureture

Governor's Square 17

## **A10** Domestic Violence and Aging Adults

Guide: **Cynthia Baker**, Regional Clinical Director, Behavioral Health, DEER OAKS, A Behavioral Health Organization

Plaza Ballroom C/F

## **A11** Changing the Culture of Aging, One Intergenerational Conversation at a Time

Guides: **Beryl Goldman**, PhD, RN, NHA

**Nancy Weber Sutter**, Professor, Chestnut Hill College; Montgomery County Community College

**William Benson**, President, Health Benefits ABCs

Monday, August 13, 2018

Concurrent Session B: 2:30PM – 4:30PM

For session descriptions and guide biographies, go to the Pioneer Network Conference App (see page 12).



Plaza Ballroom A

**B1**  
**Giving and Receiving  
Feedback: A Foundation for  
an Empowered Workforce**

Guides: Anna Ortigara, Consultant, PHI

Sue Misorski, V. P. Workforce  
Innovations, PHI



Plaza Ballroom D

**B2**  
**Dementia Care Practice  
Recommendations for Health  
Care Professionals**

Guides: Douglas Pace, Director,  
Mission Partnerships, Alzheimer's  
Association

Sam Fazio, Director, Quality Care &  
Psychosocial Research, Alzheimer's  
Association

Plaza Ballroom B/E

**B3**  
**Changing the Culture of  
Diets: Creating Person-  
Centered Menu Options for  
Heart Disease and Diabetes**

Guides: Janice Raymond, Clinical  
Nutrition Director, Thomas Cuisine  
Mgmt at Providence

Diane Hall, President & CEO, Balanced  
Senior Nutrition

Governor's Square 10

**B4**  
**Oral Care in Long-term Care:  
A Collaborative Quality  
Improvement Project**

Guides: Beth Ann White, Assistant  
Professor, The Pennsylvania State  
University

Amy Collins, Director of Nursing,  
Ohesson Manor



Governor's Square 11

**B5**  
**Music in Value Based Care:  
Research Supported, Non-  
Pharmaceutical Interventions  
for Achieving Improved  
Resident Outcomes**

Guide: Erin Spring, Co-Chair Music  
Listening Workgroup/Music Therapist,  
American Music Therapy Association

Governor's Square 12

**B6**  
**Alarms: The New Deficient  
Practice. Replacing Alarms  
and Reducing Falls with  
Better Practices**

Guide: Carmen Bowman, MHS, BSW,  
Owner, Edu-Catering

Governor's Square 14

**B7**  
**Community Care Teams —  
An Experiential Introduction  
to Person-Centered  
Behavioral Support Planning**

Guide: Kelly Carney, Corporate  
Director of Memory Care, Acts  
Retirement Life



Governor's Square 15

**B8**  
**Culture Change in the  
Experience Era**

Guides: Tammy Marshall, Chief  
Experience Officer, The New Jewish  
Home.

Stacy Palmer, Senior Vice President,  
The Beryl Institute

Governor's Square 16

**B9**  
**Trust Me-You Want to Attend  
This Session! (Hint: It's the  
Foundation for Change)**

Guide: Mel Coppola, Founder and  
President, Hearts in Care, LLC.

Governor's Square 17

**B10**  
**Examining Choice and  
Control: Practical  
Applications in Person  
Centered Discovery Planning,  
and Plan Review**

Guides: Tanya Richmond, Partner,  
Support Development Associates, LLC

Michael Smull, Partner, Support  
Development Associates, LLC

Robert Sattler, Partner, Support  
Development Associates, LLC

Plaza Ballroom C/F

**B11**  
**Care Partner and  
Environmental Design  
Collaboration for Exceptional  
Dementia Care**

Guides: Susan Gilster, Executive  
Director, The Gilster Group

Maggie Calkins, , PhD, EDAC,  
Board Chair, IDEAS Institute



Tuesday, August 14, 2018

Concurrent Session C: 8:00AM – 9:30AM

For session descriptions and guide biographies, go to the Pioneer Network Conference App (see page 12).



Plaza Ballroom A

**C1**  
**What Living as a Resident Can Teach Long Term Care Staff**

Guide: **Leslie Pedtke**, Educator for Quality Improvement, King Management Company

Session C2 has been cancelled.\*

**C2**  
**Standards for Person-Centered Dementia Care**

Guides: **Susanne Matthiesen**, MS, CARF International

**Karen Travis**, Assistant ED and Nursing Home Administrator, The Kenwood by Senior Star

*\*Susanne Matthiesen has recorded a webinar of this session. A link can be found on the App with the session information, as well as on the Pioneer Network website.*

Plaza Ballroom B/E

**C3**  
**The Person-Centered Approach to Rehab & Recovery**

Guide: **Lisa Milliken**, Director of Education, Select Rehab

Session C4 has been cancelled.\*

**C4**  
**Above & Beyond: Driving Regulatory Compliance Through the Domains of Well-Being**

Guide: **Vickie Burlew**, Health Care Consultant and Educator, Linchpin Quality Solutions, LLC

*\*Vicki Burlew has recorded a webinar of this session. A link can be found on the*

*App with the session information, as well as on the Pioneer Network website.*



Governor's Square 11

**C5**  
**How Life Storytelling Can Improve Care and Create Connections**

Guides: **Jay Newton-Small**, CEO and Founder, MemoryWell

**Juliet Holt Klinger**, Senior Director of Dementia Care and Program, Brookdale Senior Living

Governor's Square 12

**C6**  
**Awakening the Spirit Through the Arts**

Guide: **Wendy Lustbader**, Affiliate Associate Professor, University of Washington School of Social Work

**Lisa Chevalier**, Gerontologist, Lisa Chevalier Consulting

Governor's Square 14

**C7**  
**A Journey To Resident-Directed Culture: Exploring One Community's Thought Process**

Guides: **Abigail Amidon**, Music Therapist, Shenandoah Valley Westminster-Canterbury

**Donielle Weatherholtz-Palmer**, Director of Resident Services, Shenandoah Valley Westminster-Canterbury

**Robert Sherwood**, Resident, Shenandoah Valley Westminster-Canterbury



Governor's Square 15

**C8**  
**The Never-Ending Quest to Sustain Culture Change Momentum**

Guide: **Jessica Luh Kim**, Director of Education and Program Development, Schlegel Villages

**Augustin James**, Assistant General Manager, Village of Tansley Woods



Plaza Ballroom D

**C9**  
**Now is Found: Redefining Dementia Care**

Guides: **Mandy Shoemaker**, Co-Founder, Prairie Elder Care

**Michala Gibson**, Co-Founder, Director of Care, Prairie Elder Care

Governor's Square 17

**C10**  
**Identifying and Supporting Caregivers in the LGBT Community**

Guide: **Tim Johnston**, Director of National Projects, SAGE

Plaza Ballroom C/F

**C11**  
**A Life Worth Living: The Advocate's Perspective**

Guides: **Leah McMahon**, State PACE Ombudsman, Disability Law Colorado

**Jennifer Reeves**, Long-Term Care Ombudsman, Denver Regional Council of Governments



pioneernetwork.net



Tuesday, August 14, 2018

Concurrent Session D: 10:00AM – 11:30AM

For session descriptions and guide biographies, go to the Pioneer Network Conference App (see page 12).



Plaza Ballroom A

**D1**

**Creating a Culture of Caring: Addressing Recruitment and Retention Challenges Through a Workforce Development Approach**

Guide: **Hayley Gleason**, Assistant Director, Home Care Aide Council



Plaza Ballroom D

**D2**

**Building a Community of Competence and Compassion by Volunteering in Memory Care**

Guide: **Jeannine Forrest**, President, Through the Forrest, LLC

Plaza Ballroom B/E

**D3**

**Start With Yes and We Will Figure it Out From There**

Guides: **Noel Erum**, Recreation Aide for the Village at St. Clair, Schlegel Villages

**Candace Manwaring**, Neighborhood Coordinator/Personal Support Worker, Schlegel Villages

Governor's Square 10

**D4**

**The Process Behind the Passion: How your Care Community Can Support Person-Directed Care**

Guides: **Lisa Rill**, PhD, Claude Pepper Center at Florida State University

**Lori Gonzalez**, PhD, Claude Pepper Center at Florida State University

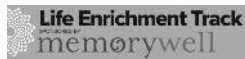

Governor's Square 11

**D5**

**It Starts with Me: One Woman's Journey of Personal Transformation on the Culture Change Journey**

Guide: **Jenni Dill**, Life Engagement Specialist, Anthem Memory Care

Governor's Square 12

**D6**

**Living Out Loud With Dementia**

Guides: **Jytte Lokvig**, Founder and Facilitator, National Alzheimers Cafe Alliance

**Susan Balkman**, Alzheimers Cafe

Governor's Square 14

**D7**

**Growing Ideas for Greater Culture Change...Planting Seeds for Empowerment**

Guide: **Pam Catlin**, Horticultural Therapist, The Growing Difference



Governor's Square 15

**D8**

**Transforming an Organization One Neighborhood at a Time**

Guides: **Chris Cox**, COO, Signature HealthCARE

**Angie McAllister**, Director of Cultural Transformation, Signature HealthCARE

Governor's Square 16

**D9**

**Empowering Elders to Maintain Life Roles**

Guides: **Chris Simons**, Director of Dementia Services, Clark Retirement Community

**Renee Van Y**, Life Enrichment Specialist, Clark Retirement Community

Governor's Square 17

**D10**

**The Lighthouse Engagement Model: A State of the Art Model of Care at Westminster-Canterbury on Chesapeake Bay**

Guides: **Dr. Victoria Crenshaw**, VP of Resident & Health Operation, Westminster-Canterbury on Chesapeake Bay

**Jennifer Melnyk**, Administrator of The Hoy Center, Westminster-Canterbury on Chesapeake Bay

**Sonya Barsness**, Gerontologist, Sonya Barsness Consulting LLC

Plaza Ballroom C/F

**D11**

**The Wisdom of the Sage: Utilizing Elder Volunteers from the Community to Achieve Your Mission**

*Sponsored by Vivage*

Guides: **Claire Lucas**, Project Guide, The Green House Project

**Lisa Bryant**, Assistant Administrator/Guide, Mirasol Senior Community

Tuesday, August 14, 2018

Concurrent Session E: 1:00PM – 2:30PM

For session descriptions and guide biographies, go to the Pioneer Network Conference App (see page 12).



Plaza Ballroom A

**E1**

### Caring for Our Staff: Maslow's Hierarchy as a Model for LTC Staff Satisfaction and Retention

Guide: **Stacey Johnson**, VP Clinical Quality and Development, Trinity Health Senior Communities



Plaza Ballroom D

**E2**

### Living with Alzheimer's — An Up Close and Personal Look at Life with Alzheimer's Disease

Guide: **Brian LeBlanc**, Advisory Board Member, Dementia Action Alliance

Plaza Ballroom B/E

**E3**

### Restore Me: A New Twist on Restorative Programming

*Sponsored by AHCA/NCAL*

Guide: **Angie McAllister**, Director of Cultural Transformation, Signature HealthCARE

**Ryan Myracle**, Hometown Culture Change Learning Manager, Signature HealthCARE

**Annette Wenzler**, Chief Nurse Executive, Signature HealthCARE

Governor's Square 14

**E4**

### How to Build a Culture of Quality Improvement Focused on the Positive

Guides: **Whitney Mills**, Research Investigator, Michael E. DeBakey VA Medical Center

**Christine Hartmann**, Researcher, Bedford VA Medical Center

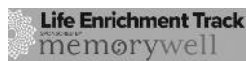

Governor's Square 11

**E5**

### Meaningful & Purposeful Living Innovations: An Enlightening Approach to Community-Based Programs and Services in Taiwan

Guides: **Angie Keeven**, Vice President, Organizational Development, Cedarhurst Living

**Li-Tzu (liz) Tu**, Executive Assistant to the Chairman, A Kernel of Wheat Foundation

Governor's Square 12

**E6**

### Namaste Care™: A Creative Person-Centered Approach for Palliative Care in a Long-Term Care Setting

Guides: **Paula McNiel**, Associate Professor, University of Wisconsin Oshkosh

**Judith Westphal**, Interim Dean, University of Wisconsin Oshkosh

Governor's Square 10

**E7**

### Championing Culture Change as a Spiritual Mastery Path

Guides: **Jeff Jerebker**, Elder-Care Influencer

**Barry Barkan**, Founder, Live Oak Institute



Governor's Square 15

**E8**

### Build This Not That: How Smaller Homes Lead to Better Outcomes

Guides: **Debbie Wiegand**, Project Guide, The Green House Project

**Rob Simonetti**, Design Director/Senior Associate, SWBR Architect

**Jodi Mason**, Interior Designer, SWBR Architects

Governor's Square 16

**E9**

### Leveraging Partnerships for Creating Dementia Inclusive Communities

Guides: **Tim Rogers**, Executive Director, Someren Glen Life Plan Community

**Pam Sullivan**, Vice-President of Communications, Christian Living Communities

**Robert Golden**, President & CEO, South Metro Denver Chamber of Commerce

Governor's Square 17

**E10**

### A Sage at Any Age: Making a Difference Through Intergenerational Engagement

Guides: **Laura Beck**, Learning and Development Guide, The Eden Alternative

**Meredith Martin**, Education Coordinator, The Eden Alternative



pioneernetwork.net



## Conference Intensives

The Intensives are a deep dive into one topic. Experienced Guides, demonstrating with hands-on practical approaches, will get to the heart and soul of the subject matter, while giving you the nuts and bolts that you can take home and use immediately. These Intensives are designed especially for YOU — the Pioneer attendee. So prepare for an interactive intense learning experience.

**Wednesday, August 15, 2018**

**Full Day Intensives: 8:00AM – 4:30PM**

For session descriptions and guide biographies, go to the **Pioneer Network Conference App** (see page 12).

Governor's Square 15

**#1**

### **From Awareness to Advocacy: From Ageism to Age Pride**

Guides: **Ashton Applewhite**, Author and Activist

**Mel Coppola**, Founder and President, Hearts in Care, LLC.

**Sr. Imelda Maurer**, cdp, In Service to Our Own

**Carmen Bowman**, MHS, BSW, Owner, Edu-Catering

Governor's Square 14

**#2**

### **Navigating the Mega Rule: Building a Highly Involved Culture of Critical Thinkers**

Guides: **Megan Hannan**, Executive Leader, Action Pact

**LaVrene Norton**, Founder, Action Pact

**Glenn Blacklock**, MA, LNHA

**Gloria Blackman**, Nurse Consultant, Action Pact

**Linda Bump**, Consultant, Action Pact

Governor's Square 16

**#3**

### **Giving Back, Not Giving Up: A Heart to Serve in Your Community**

Guides: **Michael Wasserman**, CEO, Rockport Healthcare Services

**Matthew Lysobey**, Chief Community Integration Officer, Rockport Healthcare Services

Governor's Square 9

**#4**

### **The Role of the Gerontological Nurse in Person-Centered Care**

Guides: **Cheryl Krushke**, Associate Professor, Regis University

**Mary Tellis-Nayak**, VP Quality Initiatives, MyInnerview

**Wednesday, August 15, 2018**

**Half Day Intensives AM: 8:00AM – 11:45AM**

For session descriptions and guide biographies, go to the **Pioneer Network Conference App** (see page 12).

Governor's Square 12

**#5**

**Compassionate Touch Specialist Training**

Guides: Pam Brandon, President/Founder, AGE-u-cate

V'Ann Giuffre, Vice President of Operations, AGE-u-cate Training Institute

Governor's Square 11

**#6**

**Pioneering Solutions to the Workforce Crises**

Guides: Anna Ortigara, Consultant, PHI

Sue Misiorski, V. P. Workforce Innovations, PHI

Governor's Square 10

**#7**

**Preferences for Everyday Living Inventory (PELI) Bootcamp: The Foundation for Implementing Preference Based, Person-Centered Care in Nursing Communities**

Guides: Karen Eshraghi, Quality Improvement Project Manager, Abramson Center for Jewish Life

Victoria Crumbie, Director of Recreation, Abramson Center for Jewish Life

Alexandra Heppner, Project Manager, Miami University

Governor's Square 17

**#8**

**LTC Leader's Guide to High Performance: Doing Better Together**

Guides: Barbara Frank, Co-founder, B&F Consulting

Cathie Brady, Co-founder, B&F Consulting

David Farrell, Vice President of Sub-Acute Operations, Telecare

**Wednesday, August 15, 2018**

**Half Day Intensives PM: 12:45PM – 4:30PM**

For session descriptions and guide biographies, go to the **Pioneer Network Conference App** (see page 12).

Governor's Square 11

**#9**

**Cross-Cultural Experiences of Legacy Art Work with Elders in Taiwan**

Guides: Moony Kang, CEO, New and Alive Art Service Company

Wan-Yu (Chenelle) Lin, Chair, Department of Elderly Creative Industry Management, Tajen University

Governor's Square 12

**#10**

**Person-Centered Life in Assisted Living: Navigating a Shifting Landscape**

Guides: Juliet Holt Klinger, Senior Director of Dementia Care and Program, Brookdale Senior Living

Jeanne Heid-Grubman, Administrator, Village at Victory Lakes

Governor's Square 10

**#11**

**Preferences for Everyday Living Inventory (PELI) advanced Bootcamp: Strategies for Communicating Resident/Client Important Preferences across Care Teams, Volunteers, and Families**

Guides: Karen Eshraghi, Quality Improvement Project Manager, Abramson Center for Jewish Life

Victoria Crumble, Director of Recreation, Abramson Center for Jewish Life

Alexandra Heppner, Project Manager, Miami University

Governor's Square 17

**#12**

**Bottom up Culture Change through Regenerative Community Development**

Guides: Barry Barkan, Founder, Live Oak Institute

Deborah Barkan, Co-Director, Live Oak Institute





**Board of Directors**

**CONVENER**

Carter Catlett Williams  
Gloucester, Virginia

**BOARD**

KaraLe Causey  
*President*  
COO/CFO  
Haven Nursing Center  
Columbia, LA

Todd Andrews  
*Vice President*  
Regional Vice President  
Sodexo Senior Living  
Gainesville, VA

Mary Fuentes  
*Treasurer*  
Vice President of Financial Services,  
Vivage Quality Health Partners  
(Retired)  
Denver, CO

Rodney Alderfer  
*Secretary*  
Bridgewater Retirement Community  
Bridgewater, VA

Jonathan Evans  
Nursing home physician  
Charlottesville, VA

Jessica Luh Kim  
Director of the Resident Experience  
Schlegel Villages  
Kitchener, Ontario, Canada

Juliet Holt Klinger  
Senior Director Dementia Care  
Brookdale Senior Living  
Chicago, IL

Cheryl Kruschke  
Associate Professor  
Regis University  
Denver, CO

Marguerite McLaughlin  
Consultant  
Cumberland, RI

Chris Perna  
Retired President & CEO  
The Eden Alternative  
Rochester, NY

Donald Redfoot  
Retired Policy Analyst  
AARP  
Red Lodge, MT

Ray Rusin  
CEO  
Quality Training Associates, LLC  
Woonsocket, RI

Barbara Sepich  
President/CEO  
WRC Senior Services  
Brookville, PA

Jack York  
Founder/President  
It's Never 2 Late  
Centennial, CO

**PIONEER NETWORK STAFF**

Penny Cook      President & CEO  
Joan Devine      Director of  
Education  
Cathy Lieblich    Director of  
Network Relations  
Kathy Pelletteri   Executive Assistant



Pioneer Network  
**Pioneering a  
New Culture of Aging  
Conference**

**CONFERENCE STAFF**

Carol Bassett      Graphic Designer  
Joan Devine      Conference  
Coordinator  
Misty Frank      Conference  
Manager  
Evan Frank      Conference  
Assistant  
Jill Layne      Conference  
Photographer  
Cathy Lieblich    Book Store  
Coordinator  
Kathy Pelletteri   Book Store  
Associate  
Hilda Thompson   Session  
Coordinator

**CONFERENCE SUB-COMMITTEE /  
EDUCATION COMMITTEE**

Marguerite McLaughlin, *Chair*  
Jeanne Heid-Grubman,  
*Immediate Past Chair*  
Mary Ann Anichini  
Lynda Crandall  
Thomas Grden  
Juliet Holt Klinger  
Bill Keane  
Cheryl Kruschke  
Megan Hannan  
Steven Montgomery  
Anna Ortigara  
Bob Sherwood

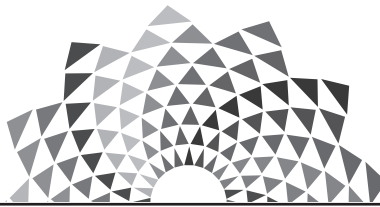

## SPECIAL THANKS TO:

### **Our Fantastic Volunteers**

for their hard work and undaunting support.

### **Presbyterian Homes of Evanston,**

for kindly hosting our Education Committee meeting in January.

### **To the Elders and staff of**

**Chelsea Place Memory Care in Aurora;  
Amberwood Court, Brookshire House and Rowan  
Community in Denver; Mirasol Senior Community  
in Loveland; and Someren Glen, Holly Creek and  
Clermont Park Christian Living Communities,**

for opening their homes up to fellow Pioneers for this year's site visits.

### **To the Elders from Christian Living Communities**

for their participation in this year's conference, serving as Guides in the Tech Experience and models for the "Look Good, Feel Good" event.

### **To Dee Deeter, Brian LeBlanc and Bill Keane**

for serving as panelists and sharing their wisdom as Elders for the Continuing the Conversation session.

### **Colorado Culture Change Coalition,**

for their hospitality as they have welcomed Pioneer Network to Colorado.



**A Special Thanks to  
Select Rehabilitation,  
the Tech Experience Sponsor,  
and to all the organizations  
who contributed to  
creating this experience.**

Eversound  
Embodied Labs  
Heart Legacy  
It's Never 2 Late  
Jintronix  
MyndVR  
Ohmni Labs  
Rekovo  
Silver Nest  
Virtu Sense





20 LOUISVILLE 19

Save the Date!  
August 4 - 7, 2019  
Galt House  
Louisville, Kentucky



Pioneer Network

**Pioneering a  
New Culture of Aging  
Conference**



**Pioneer  
Network™**

[pionearnetwork.net](http://pionearnetwork.net)





Pioneer Network

# Pioneering a New Culture of Aging Conference



## Sheraton®

DENVER DOWNTOWN HOTEL

PLAZA BUILDING  
CONCOURSE LEVEL

### Sheraton Denver Downtown Hotel

1550 Court Place  
Denver, Colorado 80202  
TEL: 303 893 3333  
FAX: 303 626 2542  
sheratondenverdowntown.com

